

SR-500LX



<http://www.kato-works.co.jp>

- Before you use the crane, study the instruction manual thoroughly and follow the instructions it contains.
- Some differences may arise between the machine delivered and the photographs in the catalog due to the country the crane will be used in or any added improvements.
Note : The specification may be changed without notice.
- The actual colors of the body and interior may appear slightly different from those shown in this catalogue due to the limitations of photography and printing.

● Contact for enquiry:

KATO KATO WORKS CO.,LTD.
QUALITY & EXPERIENCE
SINCE 1895

C03271
9.2019-2000(FB)1 Printed in Japan

SR-500LX

9-37, Higashi-ohi 1-chome, Shinagawa-ku, Tokyo, 140-0011, Japan / Tel.: Head Office: Tokyo +81 (0)3 3458-1111 Overseas Marketing Department: Tokyo +81 (0)3 3458-1115 / FAX: Tokyo +81 (0)3 3458-1163

SR-500LX

Rough Terrain Crane

Maximum lifting capacity: 51t×2.5m

Maximum boom length: 42.0m



KATO



5-section 42m long Boom



42m

- Boom lifting capacity SUPERBOOM**
- Maximum lifting capacity..... **51t×2.5m**
 - Boom length..... **10.8m~42m**
 - Maximum lifting height..... **43.2m**
 - Boom derricking angle..... **0°~84°**
 - Maximum lifting capacity at maximum boom length..... **8.0t**

2 types of telescoping modes are available



◀ Mode A Strong lifting performance
Only the 2nd section is telescoped. Followed by a synchronous extension of sections 3, 4, and 5.



◀ Mode B Stable lifting performance
Simultaneous telescoping of the 3rd, 4th and 5th sections. Next is extension of the 2nd section.

No-Jib lifting capacity is available

10.8m

84°

■ Tail slewing radius **3.9m**

at 26.4m boom **9.2m**

at 10.8m boom **7.5m**

8.6m

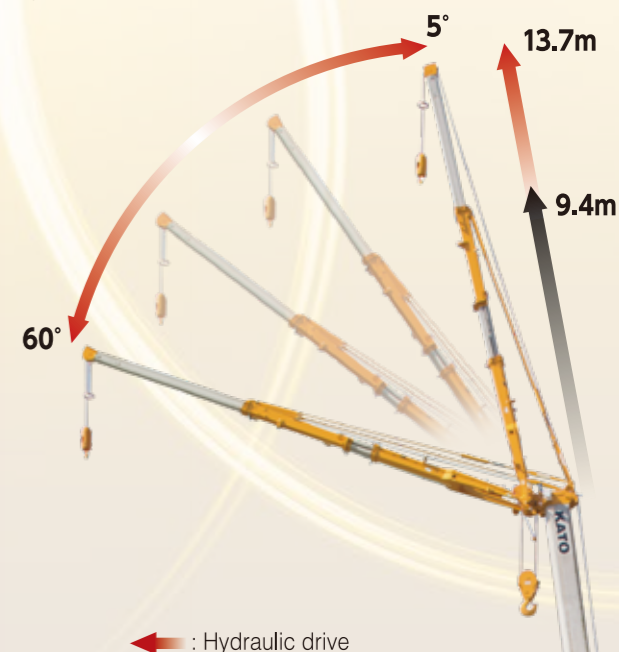

Simple mounting hydraulic telescoping/luffing Jib
Easy and user friendly mounting mechanism

Short time

Only 2 times outside work.

Small space

Less space for Jib deployment.

Safety improvement

All works will be completed on the carrier and ground.

No boom length limit for Jib deployment

It is able to avoid obstruction at Jib deployment by controlling the boom length as necessary.

● Jib lifting capacity

- Maximum lifting capacity..... **4.2t×72°**
- Jib length..... **9.4m~13.7m**
- Maximum lifting height..... **57.1m**
- Jib offset angle..... **5°~60°**



2 air conditioner ducts adopted on the front left and right side

And with a new configuration, one more has been added to the leg area.



K·COR



- The K·COR is data logger system which records working status of crane. Data is extractable by the SD card and can be confirmed through K·COR program.



▲ Multiple view colour Monitor

▼ Liquid crystal display cluster meter



(Travelling mode)



(Crane operational mode)

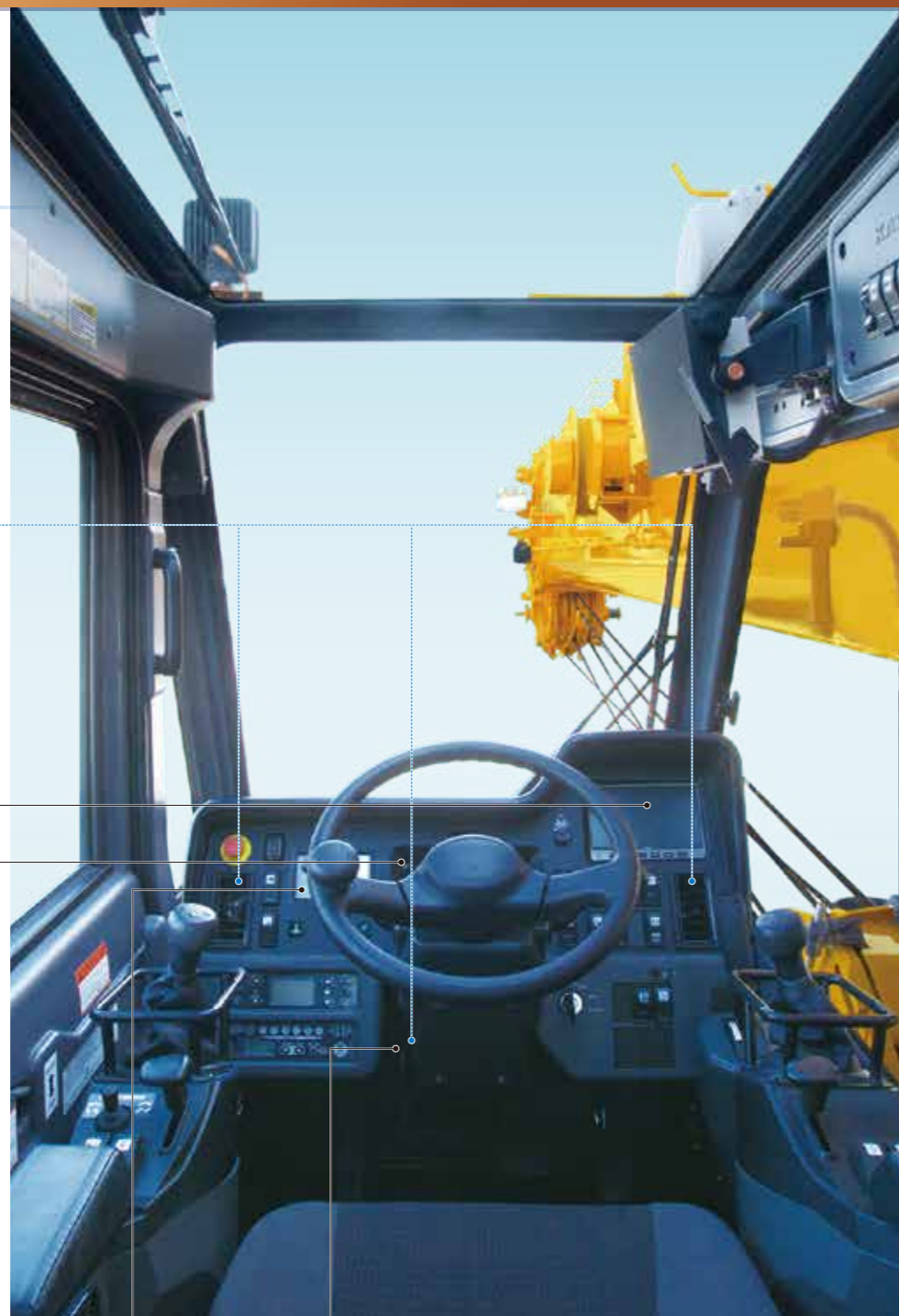

● Front leg-room air-conditioner duct

Touch screen COR information display



- The screen displays the fuel consumption, operation time, etc. and effectively improves energy saving.
- With the ECO switch, the max engine speed can be adjusted for optimum work engine speed during crane operation.
- With adoption of the Auto-Minimum Control, the hydraulic pump outlet and fuel consumption are greatly reduced during non-operation.
- Crane leveling is made easier by the newly developed electronic leveling function.



- New joystick lever
 - 6 button
 - Vibration function equipped
- New hydraulic pilot valve
 - Now in short stroke



- Lever guide
 - Supports fine operation
 - Fatigue reduction

- At hand switch arrangement improves operability



(Armrest with tele-tilt)

(Easier boarding thanks to larger tilting angle)

- Step less adjustable sun shade

New ACS moment limiter now with high resolution display

A range of limiting functions to increase Safety during Operation.



Load factor

- It limits the load factor to 80% ~ 100% of the rated lifting capacity and keep a safe margin.

Working range limit

- It can be setup to limit 2 vertical surface range to avoid collision, hence improving safety of operation.



▲ Seat with suspension and double slide

▼ New console



For various operation



Balloon tire is selectable

Balloon tires (option) secure stable travelling at off-road ground.



4-position outriggers

Ensure safe and stable operation by 4-position outriggers.

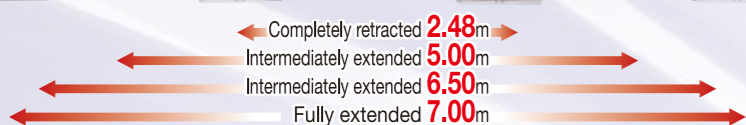

GVW is 37,075kg with radial tire. Tow hooks are equipped on the front frame. Enable to transport efficiently.

GVW : 37,075 kg
*At radial tire traveling position.



Reliable Mitsubishi engine

● Model: Mitsubishi 6M60-TL
(Electronically controlled Common-rail type)

- Piston displacement..... 7.545L
- Max power..... 200kW / 2,600min⁻¹
- Max torque..... 785N·m / 1,400min⁻¹



Progressive features



▲ Colour monitor



▲ USB socket



▲ Accessory socket



▲ Ash tray (option)



▲ Drink holder



▲ Loud speaker



▲ Side view camera (Left)



▲ Bridge device switch



▲ LED ACS outside indicator



▲ LED working light

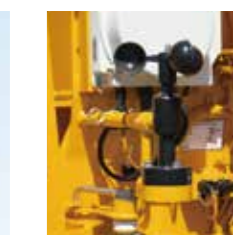

▲ Anemometer (option)

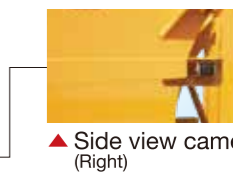

▲ Side view camera (Right)



▲ LED head light with Hi and Lo selector



▲ Electrically retractable side view mirrors



▲ Emergency switch

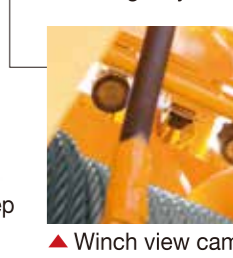

▲ Winch view camera



▲ LED combination rear light



● Boom mirror (option)



● Storage box

● Rear step



▲ LED working light (boom)



▲ LED working light (outrigger)



▲ Rear view camera

SR-500LX

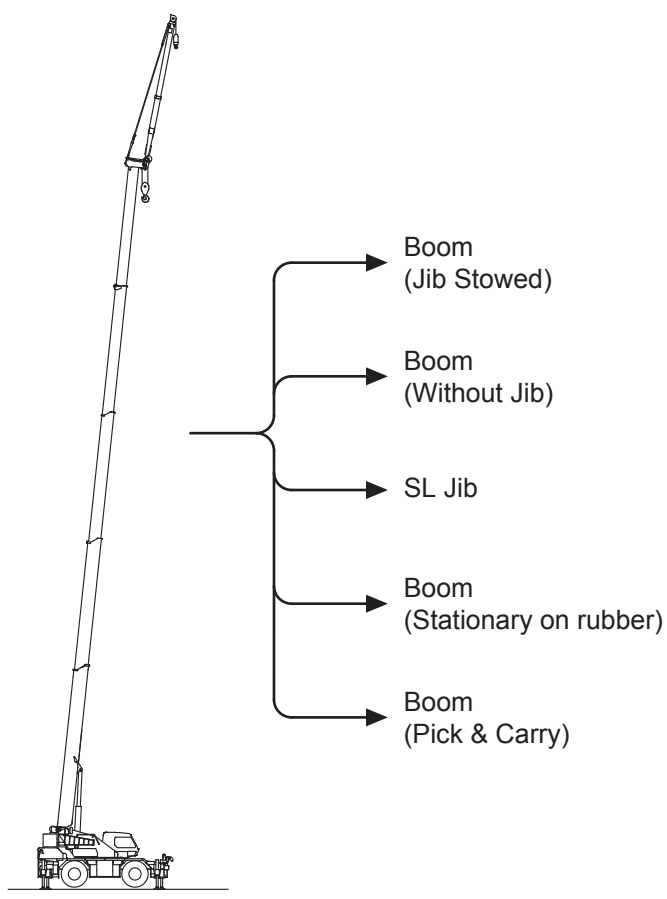

Table of Contents

SPECIFICATION	1
Notes for the lifting capacity chart	2
WORKING RANGE	3
LIFTING CAPACITY	
Boom (Jib Stowed) (Outrigger 7.0m)	5
Boom (Jib Stowed) (Outrigger 6.5m)	5
Boom (Jib Stowed) (Outrigger 5.0m)	6
Boom (Jib Stowed) (Outrigger 2.48m)	6
Boom (Without Jib) (Outrigger 7.0m)	7
Boom (Without Jib) (Outrigger 6.5m)	7
Boom (Without Jib) (Outrigger 5.0m)	8
Boom (Without Jib) (Outrigger 2.48m)	8
Boom+9.4m Jib (Outrigger 7.0m)	9
Boom+9.4m Jib (Outrigger 6.5m)	9
Boom+9.4m Jib (Outrigger 5.0m)	10
Boom+13.7m Jib (Outrigger 7.0m)	10
Boom+13.7m Jib (Outrigger 6.5m)	11
Boom+13.7m Jib (Outrigger 5.0m)	11
Stationary on rubber	12
Pick & carry	12
Minimum path width	13
Overall view	13
Overall view	14

SR-500LX

ROUGH TERRAIN CRANE



[SPECIFICATION]

■ CRANE

Description		Rough terrain crane with maximum lifting capacity 51 ton
● Crane specification		
Maximum rated lifting capacity	10.8 m Boom	51,000 kg × 2.5 m (Parts of line : 11)
	14.7 m Boom	32,000 kg × 4.5 m (Parts of line : 7)
	18.6 m Boom	26,000 kg × 5.5 m (Parts of line : 6)
	26.4 m Boom	14,000 kg × 9.0 m (Parts of line : 4)
	34.2 m Boom	13,000 kg × 8.0 m (Parts of line : 4)
	38.1 m Boom	9,500 kg × 10.0 m (Parts of line : 4)
	42.0 m Boom	8,000 kg × 11.0 m (Parts of line : 4)
	9.4 m Jib	4,200 kg × 72° (Parts of line : 1)
	13.7 m Jib	3,000 kg × 76° (Parts of line : 1)
	Rooster	5,000 kg
Boom length	10.8 m – 42.0 m (5 section)	
Jib length	9.4 m – 13.7 m (2 section, offset 5° – 60°)	
Maximum rated lifting height	43.2 m (Boom) 57.1 m (Jib)	
Hoisting line speed (winch up)	Main winch	117 m/min (at 5th layer)
	Auxiliary winch	110 m/min (at 4th layer)
Hoisting hook speed (winch up)	Main winch	(Parts of line:7) : 16.7 m/min. (at 5th layer)
	Auxiliary winch	(Parts of line:1) : 110 m/min. (at 4th layer)
High-speed lowering Rope speed	Main winch	154 m/min (at 5th layer)
	Auxiliary winch	145 m/min (at 4th layer)
Boom derricking angle	0° – 84°	
Boom derricking time	54 s / 0° – 84°	
Boom extending speed	10.8 m – 42.0 m / 108 s	
Slewing speed	2.4 min ⁻¹	
Tail slewing radius	3,900 mm	
● Equipment and structure		
Boom type	Round-shaped, 5-section hydraulically telescopic type (the 3rd, 4th and 5th boom sections at the same time)	
Jib type	2 sections (hydraulically telescopic type) Hydraulic stepless tilting type (offset angles 5° – 60°)	
Boom extension / retraction equipment	Two hydraulic cylinders and wire ropes used together	
Boom derricking / lowering equipment	One hydraulic cylinder of direct acting type with pressure-compensated flow control valve	
Winch system Main & Auxiliary winches	Driven by axial plunger type hoisting motor through planetary gear reduction. Controlled independently by 2-speed (high / low) selection type respective operating lever. Equipped with automatic brake	
Slewing equipment	Equipped with Hydraulic motor drive and a planetary gear speed reducer (built-in negative brake), Free / Lock change-over type	
Slewing bearing	Ball bearing type	
Outriggers	Type	Hydraulic H-beam type (with float and vertical cylinder in single unit)
	Extension width	7,000 mm (Fully extended)
		6,500 mm (Intermediately extended)
		5,000 mm (Intermediately extended) 2,480 mm (Completely retracted)
Wire rope for hoisting	Main winch	Diameter : 18 mm × Length : 235 m
	Auxiliary winch	Diameter : 18 mm × Length : 125 m
● Hydraulic equipment		
Oil pump	4 pumps, plunger and gear type	
Hydraulic motor	Hoisting motor	Axial plunger type
	Slewing motor	Axial plunger type
Control valve	Double acting with integral check and relief valves	
Cylinder	Double acting type	
Oil reservoir capacity	645 L	
● Safety devices		
	ACS (Automatic Crane System with voice alarm), ACS outside indicator (LED), Slewing automatic stop system, Working range limit mode, Outrigger status detector, Outrigger lock pins, Electronical horizontal detector, Boom derricking / telescoping holding valve, Jib derricking / telescoping holding valve, Overhoist prevention device, Winch holding valve, Automatic winch brake, Winch drum roller, Winch drum turning indication device, Winch over unwinding device, Hydraulic safety valves, Hydraulic oil temperature warning device, Hydraulic oil return filter warning device, Slewing lock, Slewing warning lamp, Joystick control safety stop system, Seat switch	
● Standard equipment		
	Working light (LED) on boom, table and cab, Outrigger light (LED), Winch view camera, PA system, Hook for 34 ton	
● Operator's cab		
	All steel welded construction, 1 person, 4 points viscous dumping cab suspension, Adjustable steering wheel, Adjustable seat with suspension, Seat belt, Air conditioner, Power Window (external closing switch), Front windshield wiper & washer (2 speed wiper), Roof window wiper & washer (2 speed wiper), AM/FM Radio, Interior lamp (LED), Step lamp (LED), Accessory socket (24V), USB socket (output 5V-2.4A x 2), Floor mat, K-COR (KATO Crane Operation Recorder)	
● Optional equipment		
	Slewing warning buzzer, Anemometer, Boom mirror, Air heater, Fire extinguisher, Ash tray, Hook for 51 ton	

■ CARRIER

● Carrier specification		
Maximum traveling speed	45 km/h	
Grade ability	52 % (computed at G.V.W. = 37,075 kg)	
Minimum turning radius (center of extreme outer tire)	6.7 m (4 wheel steer)	
	11.7 m (2 wheel steer)	
● Engine		
Maker	Mitsubishi	
Model	6M60-TL	
Type	4 cycle, 6 cylinders, water cooled, direct injection turbo-charged diesel engine with intercooling	
Piston displacement	7.545 L	
Max. power	200 kW at 2,600 min ⁻¹	
Max. torque	785 N·m at 1,400 min ⁻¹	
Diesel Fuel recommended by KATO must be used		
● Equipment and structure		
Drive system	Switches between 2 wheel drive (4x2) and 4 wheel drive (4x4)	
Torque converter	Engine mounted 3 elements, 1 stage (with lock up clutch)	
Transmission	Remote mounted full automatic	
Number of speeds	4 forward & 1 reverse speed (with Hi – Low selector)	
Axles	Front	Planetary, drive/steer type
	Rear	Planetary, drive/steer type
Suspension	Front & Rear	Taper – leaf spring, Hydraulic locking device with shock absorber
Brake system	Service brake	Air-over hydraulic disk brake on 4 wheels (front and rear independent circuit)
	Parking brake	Spring applied, electrically air released parking brake mounted on front axle
	Auxiliary brake	Exhaust brake, Service brake lock
Steering	Full hydraulic power steering, Completely independent front and rear steering (with automatic rear wheel steering lock system)	
Tire size	Front	505 / 95 R25 183E ROAD
	Rear	505 / 95 R25 183E ROAD
Fuel tank capacity	300 L	
Batteries	(12 V – 120 AH) × 2	
● Safety devices		
	Emergency steering device, Rear wheel steering lock system (automatic), Brake fluid leak warning device, Service brake lock, Suspension lock (& control switch), Engine overspeed alarm, Side view camera (Left & Right), Rear view camera, Electrically retractable side view mirrors, Radiator coolant level warning device, Air filter service warning device, Low air warning device	
● Standard equipment		
	Hydraulic oil cooler, LED head lamp, Aluminum outrigger plate and storage	
● Optional equipment		
	Yellow rev. light, 23.5-25-32PR Tire, Electrically retractable side view mirrors with defroster	
■ GENERAL Dimensions		
Overall length	12,760 mm	
Overall width	2,900 mm	
Overall height	3,880 mm	
Wheel base	3,800 mm	
Treads	Front	2,270 mm
	Rear	2,270 mm
Passenger capacity	One person	
Gross vehicle weight	Gross weight	approx. 37,075 kg
	Front weight	approx. 18,580 kg
	Rear weight	approx. 18,495 kg
● Stow the hooks in place before traveling.		
● Before you use this machine, read the precautions in the instruction manual thoroughly to operate it correctly.		
● KATO products and specifications are subject to improvements and changes without notice.		

Notes for the lifting capacity chart

When the outriggers are used

- The Rated Lifting Capacity of Jib stowed status and Jib removed status are different.
- The lifting capacity chart indicates the maximum load which can be lifted by this crane provided it is level and standing on firm level ground. The values in the chart include the mass of the main hook and slings for boom operation, and auxiliary hook and slings for jib operation.
[51 ton hook (mass: 490kg), 34 ton hook (mass: 360kg), 5 ton hook (mass: 120kg)]
Within the chart the figures in the area bordered with a thick line are based on structural limitations while other figures are determined by stability limitations.
- The jib working radii are based on the jib mounted on the end of 26.4m boom or the 42.0m boom.
If the boom is at any other length (more than 26.4m and less than 42.0m), use the boom angle for the 42.0m boom alone as the criterion.
If the boom length is less than 26.4m, use the boom angle for the 26.4m boom alone as the criterion.
- Do not operate the jib when the outriggers are completely retracted.
- The lifting capacities for the over sides vary with the outrigger extension width. Therefore for each outrigger extension condition you should work according to the lifting capacity chart. Use the lifting capacity chart of outriggers full extended for both front and rear areas lifting capacities.

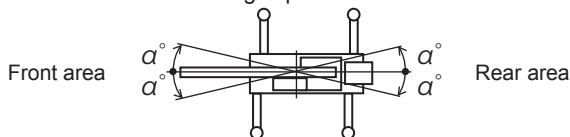

Outrigger extension status	Intermediate extension (6.5m)	Intermediate extension (5.0m)	Complete retraction
Area α°	35	30	3

- The lifting capacity of the rooster sheave is the lifting capacity of the boom minus the mass of all attached hook, slings etc. to the boom, with an upper limit of 5,000kg.
[The hook for use with the rooster sheave is the 5 ton hook (mass: 120kg) with one part of line.]
- If the boom length, boom angle, jib length, jib angle and/or working radius exceeds the rated value, use the lifting capacity for the rated value or for the next one, whichever gives the smaller lifting capacity.
- If you are working with the boom while the jib is rigged, subtract 3,500 kg plus the mass of all attached hook, slings etc. to the boom from the each lifting capacity of the boom, with an upper limit of 18 ton.
Do not use the rooster sheave in this situation. And do not operate the boom while the jib is rigged, when the outriggers are completely retracted.
- In whatever working conditions the corresponding minimum boom angle is shown in the chart. The crane can tip over if the boom is lowered below the minimum boom angle even if unloaded. Therefore, never lower the boom below these angles.
- If you work with 11 parts of line on the hook (with * marked in the lifting capacity chart), use the rooster sheave.
- The standard parts of line for each boom length are as indicated in the chart. If you work with a non-standard number of parts of line, do not exceed 45.1kN (4.6tf) per wire rope respectively.
- High-speed winch operation should only be performed to allow descent of the hook alone. Avoid sudden lever operation.
- Crane operation is permissible up to a wind speed of 10m/s. Even in relatively light wind conditions, extra care should be taken when handling loads presenting large wind catching areas.
- Kato bears no liability whatsoever for damage, crane tipping or other accident caused by crane operations which differ from the directions contained in the instruction manual and the warning labels.

When the outriggers are not used

- The Rated Lifting Capacity of Jib stowed status, Jib removed status, 505/95R25 tire status and 23.5-25-32PR tire status are same.
- The lifting capacity chart indicates the maximum load the crane can lift when its body is level on firm level ground with all tires inflated to the rated pressure and the suspension cylinder completely retracted. The values in the chart include the mass of the main hook and slings.
Within the chart the figures in the area bordered with a thick line are based on structural limitations while other figures are determined by stability limitations.
[Rated tire pressure: 505/95R25: 800kPa (8.0bar), 23.5-25: 475kPa (4.75bar)]
If you operate the crane without the suspension cylinders completely retracted, take special care that the crane does not incline and tip over.
- The working radii are the actual values allowing for boom deflection. Therefore you must always operate the crane on the basis of the working radius.
- The lifting capacity differs between the front area capacity and the full range capacity. When slewing from the front to the side, take care that the crane could not be over loaded.

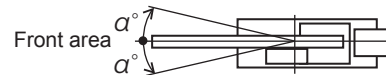

Crane operation	Stationary crane-on-rubber operation	Pick and carry operation
Area α°	1	1

- The lifting capacity of the rooster sheave is the lifting capacity of the boom minus the mass of all attached hook, slings etc. to the boom, with an upper limit of 5,000kg.
[The hook for use with the rooster sheave is the 5 ton hook (mass: 120kg) with one part of line.]
- Do not work with the jib or with a boom length of more than 26.4m.
- For stationary crane-on-rubber operation, the parking brake and service brake lock device must be engaged.
- For pick and carry operation, the high/low speed switch must be switched to "ON" (low range) and the shift lever set to speed 1.
- For pick and carry operation, lower the load to just above the ground and keep your speed strictly below 2km/h to avoid swinging the load.
Take particular care to avoid sharp turns, sudden starts and stops.
- Never operate the crane during pick and carry operation. The slewing brake must be applied.
- If the boom length, boom angle and/or working radius exceeds the rated value, use the lifting capacity for the rated value or for the next one, whichever gives the smaller lifting capacity.
- In whatever working conditions the corresponding minimum boom angle is shown in the chart. The crane can tip over if the boom is lowered below the minimum boom angle even if unloaded. Therefore, never lower the boom below these angles.
- The standard parts of line for each boom length are as indicated in the chart. If you work with a non-standard number of parts of line, do not exceed 45.1kN (4.6tf) per wire rope respectively.
- High-speed winch operation should only be performed to allow descent of the hook alone. Avoid sudden lever operation.
- Crane operation is permissible up to a wind speed of 10m/s. Even in relatively light wind conditions, extra care should be taken when handling loads presenting large wind catching areas.
- Kato bears no liability whatsoever for damage, crane tipping or other accident caused by crane operations which differ from the directions contained in the instruction manual and the warning labels.

WORKING RANGE

Telescoping mode A

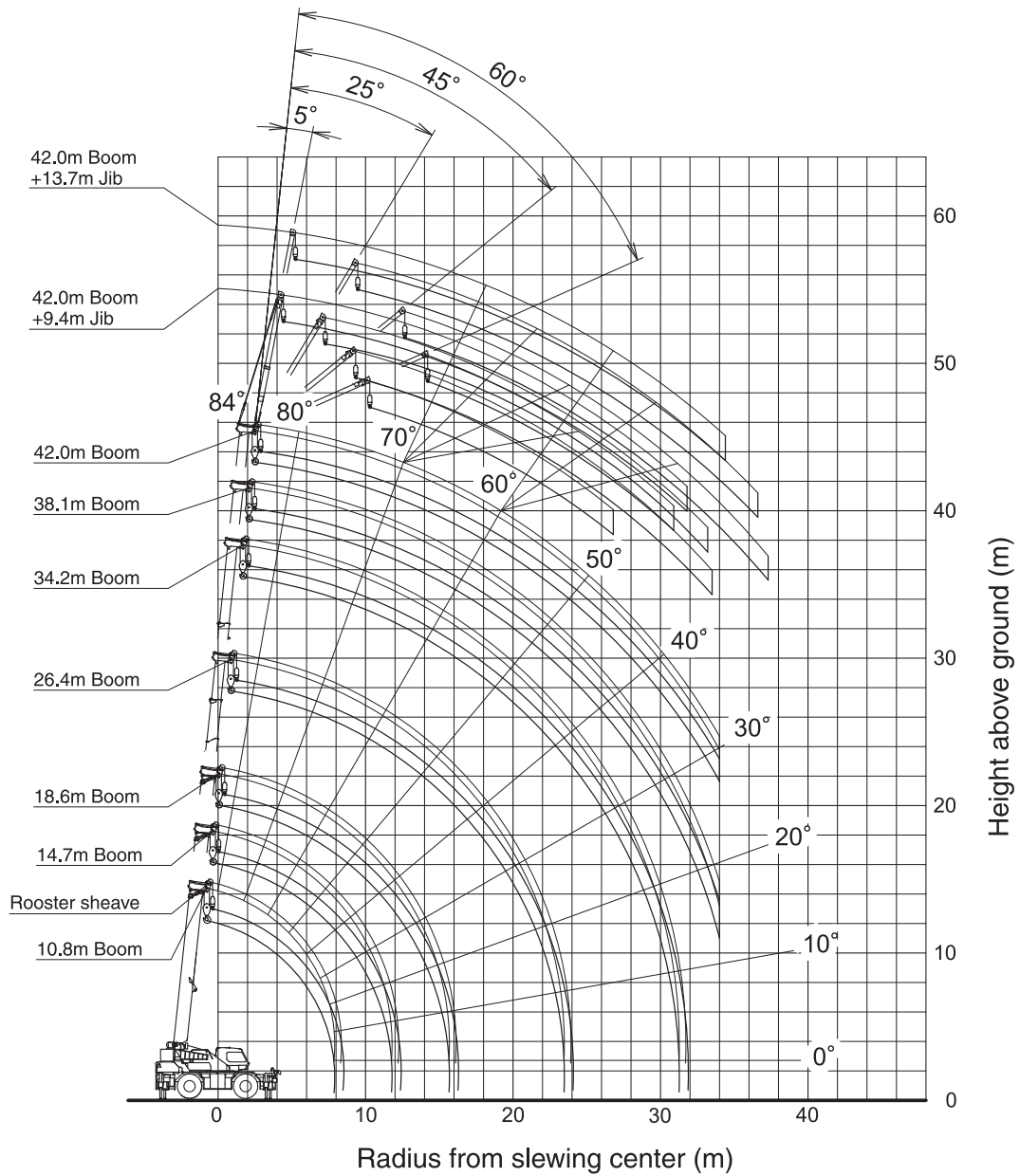

- Notes:
1. This diagram does not include deflection of Boom and Jib.
 2. The outriggers are fully extended.

Telescoping mode B

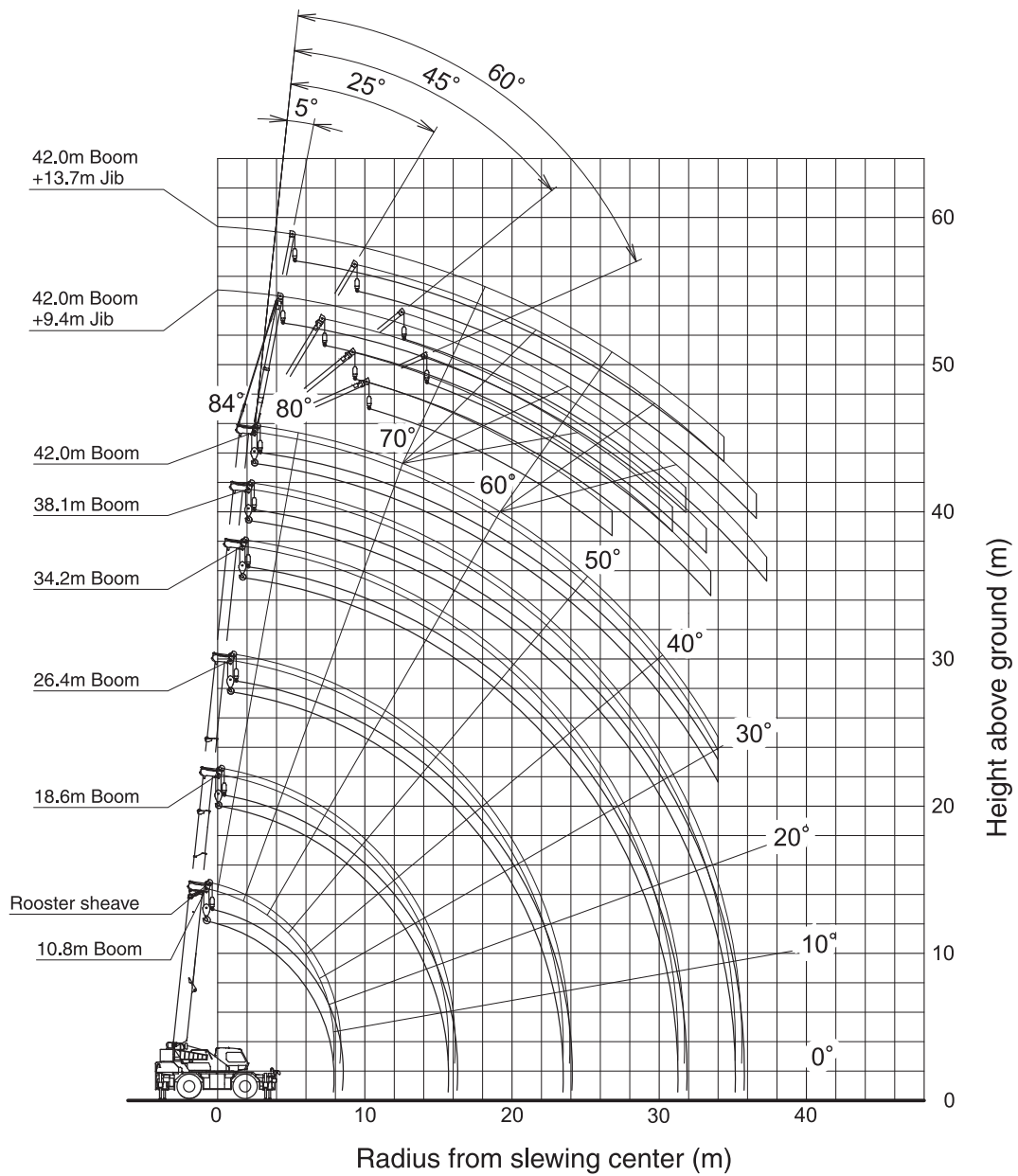

Notes:

1. This diagram does not include deflection of Boom and Jib.
2. The outriggers are fully extended.

RATED LIFTING CAPACITY

Based on ISO 4305
Not exceed 75% of static tipping loads

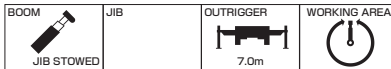

[m]	10.8	14.7	18.6		26.4		34.2		38.1		42.0	[m]
2.5	51.00	32.00	26.00	14.00	14.00	13.00	13.00	8.00				2.5
3.0	47.00	32.00	26.00	14.00	14.00	13.00	13.00	8.00	9.50	8.00		3.0
3.5	43.50	32.00	26.00	14.00	14.00	13.00	13.00	8.00	9.50	8.00	8.00	3.5
4.0	40.50	32.00	26.00	14.00	14.00	13.00	13.00	8.00	9.50	8.00	8.00	4.0
4.5	37.70	32.00	26.00	14.00	14.00	13.00	13.00	8.00	9.50	8.00	8.00	4.5
5.0	33.60	30.10	26.00	14.00	14.00	13.00	13.00	8.00	9.50	8.00	8.00	5.0
5.5	29.70	28.00	26.00	14.00	14.00	13.00	13.00	8.00	9.50	8.00	8.00	5.5
6.0	26.60	26.15	24.80	14.00	14.00	13.00	13.00	8.00	9.50	8.00	8.00	6.0
6.5	24.00	23.70	23.25	14.00	14.00	13.00	13.00	8.00	9.50	8.00	8.00	6.5
7.0	22.10	21.80	21.15	14.00	14.00	12.80	13.00	8.00	9.50	8.00	8.00	7.0
7.5	20.30	20.00	19.30	14.00	14.00	12.15	13.00	8.00	9.50	8.00	8.00	7.5
8.0		18.65	17.65	14.00	14.00	11.55	13.00	8.00	9.50	8.00	8.00	8.0
9.0		14.65	14.45	14.00	14.00	10.55	12.60	8.00	9.50	8.00	8.00	9.0
10.0		11.85	11.65	13.70	12.90	9.65	11.65	7.65	9.50	8.00	8.00	10.0
11.0		9.75	9.60	11.55	10.75	8.90	10.80	7.05	9.25	7.60	8.00	11.0
12.0			8.00	9.85	9.10	8.25	9.65	6.50	8.60	7.05	7.55	12.0
13.0			6.75	8.55	7.80	7.65	8.30	6.05	8.05	6.55	7.05	13.0
14.0			5.75	7.50	6.75	7.15	7.25	5.60	7.40	6.10	6.60	14.0
15.0			4.90	6.60	5.90	6.70	6.35	5.25	6.50	5.75	6.20	15.0
16.0					5.15	6.25	5.60	4.90	5.75	5.40	5.85	16.0
18.0					4.00	5.05	4.45	4.30	4.60	4.75	4.70	18.0
20.0					3.10	4.15	3.55	3.80	3.70	4.05	3.80	20.0
22.0					2.40	3.45	2.85	3.40	2.95	3.30	3.10	22.0
24.0							2.25	3.05	2.40	2.75	2.50	24.0
26.0							1.80	2.55	1.95	2.30	2.05	26.0
28.0							1.40	2.20	1.55	1.90	1.65	28.0
30.0							1.00	1.85	1.15	1.55	1.30	30.0
32.0									0.85	1.25	0.95	32.0
34.0									0.60	1.00	0.70	34.0
BOOM 2 [%]	0	50	100	0	100	0	100	0	100	50	100	BOOM 2 [%]
BOOM 3 [%]	0	0	0	33	33	66	66	100	83	100	100	BOOM 3 [%]
BOOM 4 [%]	0	0	0	33	33	66	66	100	83	100	100	BOOM 4 [%]
BOOM 5 [%]	0	0	0	33	33	66	66	100	83	100	100	BOOM 5 [%]
MODE	A,B	A	A	B	A	B	A	B	A	B	A,B	MODE
MIN [°]	—	—	—	—	—	—	—	—	11	—	27	[°]
CAPACITY [ton]	51								34			[ton]
MASS [kg]	490								360			[kg]
[Parts of line]	11	7	6						4			[Parts of line]

(Unit : Metric ton)



[m]	10.8	14.7	18.6		26.4		34.2		38.1		42.0	[m]
2.5	51.00	32.00	26.00	14.00	14.00	13.00	13.00	8.00				2.5
3.0	47.00	32.00	26.00	14.00	14.00	13.00	13.00	8.00	9.50	8.00		3.0
3.5	43.50	32.00	26.00	14.00	14.00	13.00	13.00	8.00	9.50	8.00	8.00	3.5
4.0	40.50	32.00	26.00	14.00	14.00	13.00	13.00	8.00	9.50	8.00	8.00	4.0
4.5	37.70	32.00	26.00	14.00	14.00	13.00	13.00	8.00	9.50	8.00	8.00	4.5
5.0	33.60	30.10	26.00	14.00	14.00	13.00	13.00	8.00	9.50	8.00	8.00	5.0
5.5	29.70	28.00	26.00	14.00	14.00	13.00	13.00	8.00	9.50	8.00	8.00	5.5
6.0	26.60	26.15	24.80	14.00	14.00	13.00	13.00	8.00	9.50	8.00	8.00	6.0
6.5	24.00	23.70	23.25	14.00	14.00	13.00	13.00	8.00	9.50	8.00	8.00	6.5
7.0	21.80	21.40	21.15	14.00	14.00	12.80	13.00	8.00	9.50	8.00	8.00	7.0
7.5	18.90	18.50	18.35	14.00	14.00	12.15	13.00	8.00	9.50	8.00	8.00	7.5
8.0		16.20	16.05	14.00	14.00	11.55	13.00	8.00	9.50	8.00	8.00	8.0
9.0		12.75	12.60	14.00	13.85	10.55	12.60	8.00	9.50	8.00	8.00	9.0
10.0		10.35	10.20	12.15	11.35	9.65	11.65	7.65	9.50	8.00	8.00	10.0
11.0		8.55	8.40	10.25	9.50	8.90	10.05	7.05	9.25	7.60	8.00	11.0
12.0			7.00	8.75	8.05	8.25	8.55	6.50	8.60	7.05	7.55	12.0
13.0			5.85	7.60	6.90	7.65	7.40	6.05	7.55	6.55	7.05	13.0
14.0			4.95	6.65	5.95	7.05	6.40	5.60	6.60	6.10	6.60	14.0
15.0			4.20	5.85	5.15	6.25	5.60	5.25	5.80	5.75	5.90	15.0
16.0					4.50	5.55	4.95	4.90	5.10	5.40	5.20	16.0
18.0					3.45	4.50	3.90	4.30	4.00	4.40	4.15	18.0
20.0					2.65	3.65	3.05	3.80	3.20	3.55	3.30	20.0
22.0					2.00	3.05	2.45	3.20	2.55	2.90	2.65	22.0
24.0							1.90	2.65	2.05	2.40	2.15	24.0
26.0							1.50	2.25	1.60	1.95	1.70	26.0
28.0							1.10	1.90	1.20	1.60	1.35	28.0
30.0							0.75	1.60	0.90	1.25	1.00	30.0
32.0									0.60	0.95	0.70	32.0
34.0										0.75		34.0
BOOM 2 [%]	0	50	100	0	100	0	100	0	100	50	100	BOOM 2 [%]
BOOM 3 [%]	0	0	0	33	33	66	66	100	83	100	100	BOOM 3 [%]
BOOM 4 [%]	0	0	0	33	33	66	66	100	83	100	100	BOOM 4 [%]
BOOM 5 [%]	0	0	0	33	33	66	66	100	83	100	100	BOOM 5 [%]
MODE	A,B	A	A	B	A	B	A	B	A	B	A,B	MODE
MIN [°]	—	—	—	—	—	—	—	—	24	—	33	[°]
CAPACITY [ton]	51								34			[ton]
MASS [kg]	490								360			[kg]
[Parts of line]	11	7	6						4			[Parts of line]

(Unit : Metric ton)

Based on ISO 4305
Not exceed 75% of static tipping loads

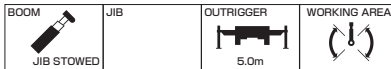

[m]	10.8	14.7	18.6		26.4		34.2		38.1		42.0	[m]
2.5	51.00	32.00	26.00	14.00	14.00	13.00	13.00	8.00				2.5
3.0	47.00	32.00	26.00	14.00	14.00	13.00	13.00	8.00	9.50	8.00		3.0
3.5	41.80	32.00	26.00	14.00	14.00	13.00	13.00	8.00	9.50	8.00	8.00	3.5
4.0	37.50	32.00	26.00	14.00	14.00	13.00	13.00	8.00	9.50	8.00	8.00	4.0
4.5	34.00	32.00	26.00	14.00	14.00	13.00	13.00	8.00	9.50	8.00	8.00	4.5
5.0	26.80	26.45	26.00	14.00	14.00	13.00	13.00	8.00	9.50	8.00	8.00	5.0
5.5	21.90	21.55	21.45	14.00	14.00	13.00	13.00	8.00	9.50	8.00	8.00	5.5
6.0	18.35	18.05	17.95	14.00	14.00	13.00	13.00	8.00	9.50	8.00	8.00	6.0
6.5	15.70	15.40	15.25	14.00	14.00	13.00	13.00	8.00	9.50	8.00	8.00	6.5
7.0	13.65	13.30	13.20	14.00	14.00	12.80	13.00	8.00	9.50	8.00	8.00	7.0
7.5	11.95	11.65	11.50	13.50	12.75	12.15	13.00	8.00	9.50	8.00	8.00	7.5
8.0		10.25	10.15	12.05	11.30	11.55	11.85	8.00	9.50	8.00	8.00	8.0
9.0		8.15	8.00	9.80	9.10	10.30	9.65	8.00	9.50	8.00	8.00	9.0
10.0		6.55	6.45	8.15	7.45	8.60	7.95	7.65	8.15	8.00	8.00	10.0
11.0		5.40	5.25	6.90	6.20	7.30	6.70	7.05	6.85	7.25	7.00	11.0
12.0			4.30	5.90	5.20	6.30	5.70	6.50	5.85	6.20	6.00	12.0
13.0			3.50	5.10	4.40	5.45	4.90	5.65	5.05	5.40	5.15	13.0
14.0			2.85	4.40	3.75	4.80	4.20	5.00	4.35	4.70	4.45	14.0
15.0			2.35	3.85	3.20	4.20	3.65	4.40	3.80	4.10	3.90	15.0
16.0					2.75	3.75	3.15	3.90	3.30	3.65	3.40	16.0
18.0					1.95	2.95	2.35	3.10	2.50	2.85	2.60	18.0
20.0					1.40	2.35	1.75	2.50	1.90	2.20	2.00	20.0
22.0						0.85	1.85	1.30	2.00	1.40	1.75	22.0
24.0								0.85	1.60	1.00	1.35	24.0
26.0									1.30		1.00	26.0
28.0									1.00		0.70	28.0
30.0									0.75			30.0
BOOM 2 [%]	0	50	100	0	100	0	100	0	100	50	100	BOOM 2 [%]
BOOM 3 [%]	0	0	0	33	33	66	66	100	83	100	100	BOOM 3 [%]
BOOM 4 [%]	0	0	0	33	33	66	66	100	83	100	100	BOOM 4 [%]
BOOM 5 [%]	0	0	0	33	33	66	66	100	83	100	100	BOOM 5 [%]
MODE	A,B	A	A	B	A	B	A	B	A	B	A,B	MODE
MIN [°]	—	—	—	—	—	—	36	—	45	35	50	[°]
CAPACITY [ton]	51							34				[ton]
MASS [kg]	490							360				[kg]
[Parts of line]	11	7	6					4				[Parts of line]

(Unit : Metric ton)

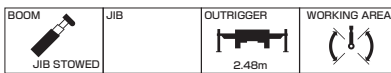

[m]	10.8	14.7	18.6		26.4		34.2		38.1		42.0	[m]
2.5	32.55	29.00	25.75	14.00	14.00	13.00	13.00	8.00				2.5
3.0	22.85	22.40	20.20	14.00	14.00	13.00	13.00	8.00	9.50	8.00		3.0
3.5	17.25	17.10	16.35	14.00	13.40	13.00	12.05	8.00	9.50	8.00	8.00	3.5
4.0	13.65	13.45	13.45	14.00	11.50	13.00	10.55	8.00	9.50	8.00	8.00	4.0
4.5	11.10	10.90	10.85	12.80	9.95	11.55	9.25	8.00	8.90	8.00	8.00	4.5
5.0	9.25	9.00	8.95	10.80	8.70	10.25	8.20	8.00	7.90	8.00	7.60	5.0
5.5	7.80	7.55	7.50	9.25	7.65	9.15	7.30	8.00	7.05	7.55	6.80	5.5
6.0	6.65	6.40	6.35	8.00	6.75	8.20	6.50	7.60	6.30	6.80	6.10	6.0
6.5	5.70	5.50	5.40	7.00	5.95	7.40	5.80	6.90	5.70	6.15	5.50	6.5
7.0	4.95	4.70	4.60	6.20	5.30	6.65	5.20	6.25	5.10	5.60	5.00	7.0
7.5	4.30	4.05	3.95	5.50	4.70	5.90	4.70	5.75	4.60	5.05	4.50	7.5
8.0		3.50	3.40	4.90	4.15	5.30	4.20	5.25	4.15	4.60	4.10	8.0
9.0		2.60	2.50	3.95	3.25	4.35	3.40	4.40	3.40	3.85	3.35	9.0
10.0		1.90	1.80	3.20	2.55	3.55	2.75	3.75	2.75	3.20	2.75	10.0
11.0		1.35	1.20	2.60	1.95	2.95	2.20	3.15	2.25	2.65	2.25	11.0
12.0				2.15	1.45	2.50	1.70	2.65	1.75	2.20	1.80	12.0
13.0				1.75		2.05		2.25		1.80		13.0
14.0				1.40		1.70		1.90		1.45		14.0
15.0				1.10		1.45		1.60				15.0
16.0						1.20		1.35				16.0
18.0						0.75		0.90				18.0
BOOM 2 [%]	0	50	100	0	100	0	100	0	100	50	100	BOOM 2 [%]
BOOM 3 [%]	0	0	0	33	33	66	66	100	83	100	100	BOOM 3 [%]
BOOM 4 [%]	0	0	0	33	33	66	66	100	83	100	100	BOOM 4 [%]
BOOM 5 [%]	0	0	0	33	33	66	66	100	83	100	100	BOOM 5 [%]
MODE	A,B	A	A	B	A	B	A	B	A	B	A,B	MODE
MIN [°]	—	—	45	—	58	37	66	55	69	65	71	[°]
CAPACITY [ton]	51							34				[ton]
MASS [kg]	490							360				[kg]
[Parts of line]	11	7	6					4				[Parts of line]

(Unit : Metric ton)

Based on ISO 4305
Not exceed 75% of static tipping loads

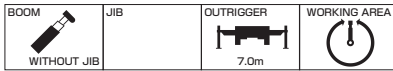

[m]	10.8	14.7	18.6		26.4		34.2		38.1		42.0	[m]
2.5	51.00	32.00	26.00	14.00	14.00	13.00	13.00	8.00				2.5
3.0	47.00	32.00	26.00	14.00	14.00	13.00	13.00	8.00	9.50	8.00		3.0
3.5	43.50	32.00	26.00	14.00	14.00	13.00	13.00	8.00	9.50	8.00	8.00	3.5
4.0	40.50	32.00	26.00	14.00	14.00	13.00	13.00	8.00	9.50	8.00	8.00	4.0
4.5	37.70	32.00	26.00	14.00	14.00	13.00	13.00	8.00	9.50	8.00	8.00	4.5
5.0	33.60	30.10	26.00	14.00	14.00	13.00	13.00	8.00	9.50	8.00	8.00	5.0
5.5	29.70	28.00	26.00	14.00	14.00	13.00	13.00	8.00	9.50	8.00	8.00	5.5
6.0	26.60	26.15	24.80	14.00	14.00	13.00	13.00	8.00	9.50	8.00	8.00	6.0
6.5	24.00	23.70	23.25	14.00	14.00	13.00	13.00	8.00	9.50	8.00	8.00	6.5
7.0	22.10	21.80	21.15	14.00	14.00	12.80	13.00	8.00	9.50	8.00	8.00	7.0
7.5	20.30	20.00	19.30	14.00	14.00	12.15	13.00	8.00	9.50	8.00	8.00	7.5
8.0		18.30	17.65	14.00	14.00	11.55	13.00	8.00	9.50	8.00	8.00	8.0
9.0		14.40	14.10	14.00	14.00	10.55	12.60	8.00	9.50	8.00	8.00	9.0
10.0		11.70	11.40	13.45	12.45	9.65	11.65	7.65	9.50	8.00	8.00	10.0
11.0		9.70	9.40	11.35	10.40	8.90	10.80	7.05	9.25	7.60	8.00	11.0
12.0			7.90	9.70	8.85	8.25	9.30	6.50	8.60	7.05	7.55	12.0
13.0			6.65	8.45	7.60	7.65	8.05	6.05	8.05	6.55	7.05	13.0
14.0			5.70	7.40	6.55	7.15	7.00	5.60	7.15	6.10	6.60	14.0
15.0			4.85	6.55	5.75	6.70	6.15	5.25	6.30	5.75	6.20	15.0
16.0					5.00	6.15	5.45	4.90	5.55	5.40	5.65	16.0
18.0						3.90	4.95	4.30	4.30	4.40	4.75	18.0
20.0						3.05	4.10	3.45	3.80	3.55	3.90	20.0
22.0						2.40	3.45	2.75	3.40	2.85	3.20	22.0
24.0								2.20	3.00	2.35	2.65	24.0
26.0								1.75	2.55	1.90	2.20	26.0
28.0								1.35	2.15	1.50	1.85	28.0
30.0								1.00	1.85	1.15	1.55	30.0
32.0									0.85	1.25	0.95	32.0
34.0									0.60	0.95	0.70	34.0
BOOM 2 [%]	0	50	100	0	100	0	100	0	100	50	100	BOOM 2 [%]
BOOM 3 [%]	0	0	0	33	33	66	66	100	83	100	100	BOOM 3 [%]
BOOM 4 [%]	0	0	0	33	33	66	66	100	83	100	100	BOOM 4 [%]
BOOM 5 [%]	0	0	0	33	33	66	66	100	83	100	100	BOOM 5 [%]
MODE	A,B	A	A	B	A	B	A	B	A	B	A,B	MODE
MIN [°]	—	—	—	—	—	—	—	—	11	—	27	[°]
CAPACITY [ton]	51								34			[ton]
MASS [kg]	490								360			[kg]
[Parts of line]	11	7	6						4			[Parts of line]

(Unit : Metric ton)

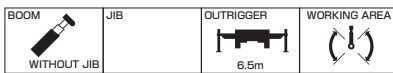

[m]	10.8	14.7	18.6		26.4		34.2		38.1		42.0	[m]
2.5	51.00	32.00	26.00	14.00	14.00	13.00	13.00	8.00				2.5
3.0	47.00	32.00	26.00	14.00	14.00	13.00	13.00	8.00	9.50	8.00		3.0
3.5	43.50	32.00	26.00	14.00	14.00	13.00	13.00	8.00	9.50	8.00	8.00	3.5
4.0	40.50	32.00	26.00	14.00	14.00	13.00	13.00	8.00	9.50	8.00	8.00	4.0
4.5	37.70	32.00	26.00	14.00	14.00	13.00	13.00	8.00	9.50	8.00	8.00	4.5
5.0	33.60	30.10	26.00	14.00	14.00	13.00	13.00	8.00	9.50	8.00	8.00	5.0
5.5	29.70	28.00	26.00	14.00	14.00	13.00	13.00	8.00	9.50	8.00	8.00	5.5
6.0	26.60	26.15	24.80	14.00	14.00	13.00	13.00	8.00	9.50	8.00	8.00	6.0
6.5	24.00	23.70	23.25	14.00	14.00	13.00	13.00	8.00	9.50	8.00	8.00	6.5
7.0	21.65	20.95	20.65	14.00	14.00	12.80	13.00	8.00	9.50	8.00	8.00	7.0
7.5	18.85	18.15	17.85	14.00	14.00	12.15	13.00	8.00	9.50	8.00	8.00	7.5
8.0		15.90	15.60	14.00	14.00	11.55	13.00	8.00	9.50	8.00	8.00	8.0
9.0		12.60	12.30	14.00	13.40	10.55	12.60	8.00	9.50	8.00	8.00	9.0
10.0		10.25	9.95	11.90	11.00	9.65	11.50	7.65	9.50	8.00	8.00	10.0
11.0		8.50	8.20	10.10	9.20	8.90	9.65	7.05	9.25	7.60	8.00	11.0
12.0			6.85	8.65	7.80	8.25	8.25	6.50	8.40	7.05	7.55	12.0
13.0			5.80	7.50	6.70	7.65	7.10	6.05	7.25	6.55	7.05	13.0
14.0			4.90	6.60	5.80	6.90	6.20	5.60	6.35	6.10	6.45	14.0
15.0			4.20	5.85	5.05	6.10	5.45	5.25	5.55	5.75	5.70	15.0
16.0					4.40	5.45	4.80	4.90	4.90	5.30	5.00	16.0
18.0						3.40	4.40	3.75	4.30	3.90	4.25	18.0
20.0						2.60	3.65	2.95	3.75	3.10	3.45	20.0
22.0						2.00	3.00	2.35	3.10	2.45	2.80	22.0
24.0								1.85	2.60	2.00	2.30	24.0
26.0								1.45	2.20	1.55	1.90	26.0
28.0								1.05	1.85	1.20	1.55	28.0
30.0								0.75	1.60	0.85	1.25	30.0
32.0									0.60	0.95	0.70	32.0
34.0										0.75		34.0
BOOM 2 [%]	0	50	100	0	100	0	100	0	100	50	100	BOOM 2 [%]
BOOM 3 [%]	0	0	0	33	33	66	66	100	83	100	100	BOOM 3 [%]
BOOM 4 [%]	0	0	0	33	33	66	66	100	83	100	100	BOOM 4 [%]
BOOM 5 [%]	0	0	0	33	33	66	66	100	83	100	100	BOOM 5 [%]
MODE	A,B	A	A	B	A	B	A	B	A	B	A,B	MODE
MIN [°]	—	—	—	—	—	—	—	—	24	—	33	[°]
CAPACITY [ton]	51								34			[ton]
MASS [kg]	490								360			[kg]
[Parts of line]	11	7	6						4			[Parts of line]

(Unit : Metric ton)

Based on ISO 4305
Not exceed 75% of static tipping loads

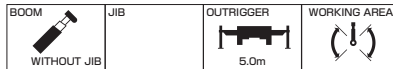

[m]		10.8	14.7	18.6		26.4		34.2		38.1		42.0	[m]
	2.5	51.00	32.00	26.00	14.00	14.00	13.00	13.00	8.00				2.5
	3.0	47.00	32.00	26.00	14.00	14.00	13.00	13.00	8.00	9.50	8.00		3.0
	3.5	41.80	32.00	26.00	14.00	14.00	13.00	13.00	8.00	9.50	8.00	8.00	3.5
	4.0	37.50	32.00	26.00	14.00	14.00	13.00	13.00	8.00	9.50	8.00	8.00	4.0
	4.5	33.55	32.00	26.00	14.00	14.00	13.00	13.00	8.00	9.50	8.00	8.00	4.5
	5.0	26.50	25.80	25.45	14.00	14.00	13.00	13.00	8.00	9.50	8.00	8.00	5.0
	5.5	21.70	21.10	20.80	14.00	14.00	13.00	13.00	8.00	9.50	8.00	8.00	5.5
	6.0	18.25	17.65	17.40	14.00	14.00	13.00	13.00	8.00	9.50	8.00	8.00	6.0
	6.5	15.70	15.10	14.85	14.00	14.00	13.00	13.00	8.00	9.50	8.00	8.00	6.5
	7.0	13.65	13.10	12.80	14.00	13.95	12.80	13.00	8.00	9.50	8.00	8.00	7.0
	7.5	12.05	11.45	11.20	13.20	12.30	12.15	12.50	8.00	9.50	8.00	8.00	7.5
	8.0		10.15	9.90	11.80	10.90	11.55	11.40	8.00	9.50	8.00	8.00	8.0
	9.0		8.10	7.85	9.65	8.80	10.00	9.25	8.00	9.45	8.00	8.00	9.0
	10.0		6.55	6.30	8.05	7.20	8.35	7.65	7.65	7.85	8.00	7.95	10.0
	11.0		5.40	5.15	6.80	6.00	7.15	6.45	7.05	6.60	6.95	6.70	11.0
	12.0			4.25	5.85	5.10	6.15	5.50	6.30	5.60	6.00	5.75	12.0
	13.0			3.50	5.05	4.30	5.35	4.70	5.50	4.85	5.20	4.95	13.0
	14.0			2.90	4.40	3.65	4.70	4.05	4.85	4.20	4.55	4.30	14.0
	15.0			2.35	3.90	3.15	4.15	3.50	4.30	3.65	4.00	3.75	15.0
	16.0					2.70	3.65	3.05	3.80	3.15	3.50	3.25	16.0
18.0					1.95	2.90	2.30	3.05	2.40	2.75	2.50	18.0	
20.0					1.40	2.35	1.70	2.45	1.85	2.15	1.90	20.0	
22.0						0.85	1.90	1.25	2.00	1.35	1.70	1.45	22.0
24.0								0.85	1.60	1.00	1.30	1.10	24.0
26.0									1.30		1.00		26.0
28.0									1.05		0.70		28.0
30.0									0.80				30.0
	BOOM 2 [%]	0	50	100	0	100	0	100	0	100	50	100	BOOM 2 [%]
	BOOM 3 [%]	0	0	0	33	33	66	66	100	83	100	100	BOOM 3 [%]
	BOOM 4 [%]	0	0	0	33	33	66	66	100	83	100	100	BOOM 4 [%]
	BOOM 5 [%]	0	0	0	33	33	66	66	100	83	100	100	BOOM 5 [%]
	MODE	A,B	A	A	B	A	B	A	B	A	B	A,B	MODE
	MIN [°]	—	—	—	—	—	—	36	—	45	35	51	[°]
	CAPACITY [ton]	51						34					[ton]
	MASS [kg]	490						360					[kg]
	[Parts of line]	11	7	6				4					[Parts of line]

(Unit : Metric ton)

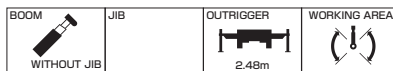

[m]		10.8	14.7	18.6		26.4		34.2		38.1		42.0	[m]
	2.5	31.90	28.15	24.80	14.00	14.00	13.00	13.00	8.00				2.5
	3.0	22.50	21.85	19.50	14.00	14.00	13.00	13.00	8.00	9.50	8.00		3.0
	3.5	17.10	16.60	15.80	14.00	12.85	13.00	11.50	8.00	9.50	8.00	8.00	3.5
	4.0	13.55	13.10	12.95	14.00	11.05	12.65	10.05	8.00	9.50	8.00	8.00	4.0
	4.5	11.10	10.65	10.50	12.45	9.55	11.15	8.85	8.00	8.45	8.00	8.00	4.5
	5.0	9.30	8.85	8.70	10.50	8.35	9.90	7.80	8.00	7.50	8.00	7.20	5.0
	5.5	7.90	7.45	7.30	9.00	7.35	8.85	6.95	8.00	6.70	7.20	6.45	5.5
	6.0	6.80	6.35	6.15	7.85	6.50	7.95	6.20	7.30	6.00	6.50	5.80	6.0
	6.5	5.90	5.45	5.25	6.90	5.75	7.20	5.55	6.60	5.40	5.90	5.25	6.5
	7.0	5.15	4.70	4.50	6.10	5.10	6.40	5.00	6.05	4.85	5.35	4.75	7.0
	7.5	4.50	4.10	3.90	5.40	4.50	5.75	4.45	5.50	4.40	4.85	4.30	7.5
	8.0		3.55	3.35	4.85	4.00	5.15	4.00	5.05	3.95	4.40	3.85	8.0
	9.0		2.65	2.45	3.95	3.15	4.20	3.25	4.25	3.25	3.70	3.15	9.0
	10.0		2.00	1.80	3.20	2.50	3.50	2.60	3.60	2.60	3.05	2.60	10.0
	11.0			1.45	2.65	1.90	2.90	2.10	3.05	2.10	2.55	2.10	11.0
	12.0				2.20	1.45	2.45	1.65	2.55	1.70	2.10		12.0
	13.0				1.80		2.05		2.15		1.75		13.0
	14.0				1.50		1.70		1.85		1.40		14.0
	15.0				1.20		1.45		1.55				15.0
	16.0						1.20		1.30				16.0
18.0						0.80		0.90				18.0	
	BOOM 2 [%]	0	50	100	0	100	0	100	0	100	50	100	BOOM 2 [%]
	BOOM 3 [%]	0	0	0	33	33	66	66	100	83	100	100	BOOM 3 [%]
	BOOM 4 [%]	0	0	0	33	33	66	66	100	83	100	100	BOOM 4 [%]
	BOOM 5 [%]	0	0	0	33	33	66	66	100	83	100	100	BOOM 5 [%]
	MODE	A,B	A	A	B	A	B	A	B	A	B	A,B	MODE
	MIN [°]	—	—	42	—	58	34	66	55	69	65	72	[°]
	CAPACITY [ton]	51						34					[ton]
	MASS [kg]	490						360					[kg]
	[Parts of line]	11	7	6				4					[Parts of line]

(Unit : Metric ton)

Based on ISO 4305
Not exceed 75% of static tipping loads

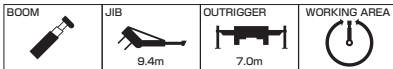

[m]	26.4								42.0																											
	5				25				45				60				[°]				5				25				45				60			
	[m]		[ton]		[m]		[ton]		[m]		[ton]		[m]		[ton]		[m]		[ton]		[m]		[ton]		[m]		[ton]		[m]		[ton]					
84	3.0	4.20	5.9	3.40	8.0	2.20	8.9	1.50	84	3.0	4.20	6.1	3.40	8.1	2.20	8.9	1.50	84	5.7	3.80	9.0	3.40	10.8	2.15	11.4	1.50										
83	3.7	4.20	6.6	3.40	8.6	2.15	9.4	1.50	83	3.7	4.20	6.7	3.40	8.6	2.15	9.4	1.50	81	8.9	3.80	11.9	3.10	13.4	2.05	13.9	1.50										
80	5.6	4.20	8.4	3.20	10.2	2.10	10.9	1.50	80	5.7	4.20	8.5	3.20	10.3	2.10	11.0	1.50	79	11.0	3.80	13.7	2.95	15.2	2.00	15.6	1.50										
77	7.5	4.20	10.2	3.00	11.8	2.00	12.4	1.50	77	7.6	4.20	10.2	2.95	11.9	2.00	12.5	1.50	76	14.1	3.80	16.5	2.80	17.7	1.95	18.0	1.45										
74	9.4	4.20	11.9	2.80	13.4	1.95	13.9	1.50	74	9.5	4.20	11.9	2.80	13.4	1.95	13.9	1.50	73	16.9	3.35	19.1	2.60	20.1	1.90	20.3	1.45										
72	10.7	4.20	13.0	2.70	14.4	1.90	14.8	1.45	72	10.8	4.20	13.0	2.70	14.5	1.90	14.8	1.45	70	19.5	2.90	21.6	2.35	22.5	1.85	22.6	1.40										
70	11.9	4.05	14.1	2.60	15.5	1.90	15.7	1.45	70	12.0	4.00	14.1	2.60	15.5	1.90	15.7	1.45	67	22.0	2.50	24.0	2.10	24.8	1.80	24.7	1.40										
67	13.6	3.65	15.8	2.45	16.9	1.85	17.1	1.45	67	13.7	3.65	15.7	2.50	16.9	1.85	17.1	1.45	65	23.5	2.25	25.5	1.95	26.3	1.80	26.1	1.40										
65	14.8	3.45	16.8	2.40	17.9	1.85	18.0	1.45	65	14.8	3.45	16.8	2.40	17.9	1.85	17.9	1.45	64	24.3	2.15	26.2	1.85	27.0	1.75	26.8	1.40										
63	15.9	3.25	17.8	2.35	18.8	1.80	18.8	1.40	63	15.9	3.25	17.8	2.35	18.8	1.80	18.8	1.40	61	26.5	1.70	28.3	1.55	29.0	1.50												
60	17.5	3.05	19.3	2.25	20.1	1.80			60	17.5	3.00	19.3	2.25	20.1	1.80			57	29.2	1.10	30.8	1.05	31.3	1.00												
57	19.0	2.80	20.7	2.20	21.3	1.80			57	19.1	2.80	20.7	2.20	21.3	1.80			53	31.8	0.65	33.2	0.65	33.5	0.65												
54	20.5	2.65	22.1	2.10	22.5	1.80			55	20.1	2.70	21.6	2.15	22.1	1.80																					
51	21.9	2.50	23.3	2.05	23.6	1.80			53	21.1	2.60	22.4	2.10	22.9	1.80																					
48	23.3	2.25	24.5	2.05	24.6	1.80			50	22.4	2.45	23.7	2.05	23.9	1.80																					
47	23.7	2.15	24.9	2.00	25.0	1.80			47	23.7	2.30	24.8	2.00	24.9	1.80																					
45	24.5	1.95	25.6	1.85					45	24.6	2.20	25.6	2.00																							
40	26.4	1.50	27.2	1.45					40	26.5	1.95	27.2	1.85																							
35	28.1	1.15	28.7	1.15					35	28.2	1.80	28.6	1.70																							
30	29.6	0.85	29.9	0.85					32	29.1	1.70	29.3	1.65																							
26	30.5	0.65	30.6	0.65					29	29.9	1.60	30.0	1.60																							
20	31.7	0.45							26	30.6	1.45	30.5	1.45																							
15	32.4	0.35							20	31.8	1.25																									
									15	32.5	1.15																									
[m]	BOOM 2 [%]	100								BOOM 2 [%]	0								BOOM 2 [%]	100																
	BOOM 3 [%]	33								BOOM 3 [%]	66								BOOM 3 [%]	100																
	BOOM 4 [%]	33								BOOM 4 [%]	66								BOOM 4 [%]	100																
	BOOM 5 [%]	33								BOOM 5 [%]	66								BOOM 5 [%]	100																
	MODE	A								MODE	B								MODE	A,B																
MIN [°]	14	25	46	62	MIN [°]	14	25	46	62	MIN [°]	52	52	52	63																						
CAPACITY [ton]	5								[ton]	5								[ton]	5																	
MASS [kg]	120								[kg]	120								[kg]	120																	
[Parts of line]	1								[Parts of line]	1								[Parts of line]	1																	

(Unit : Metric ton)

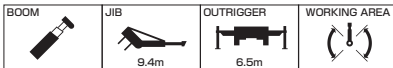

[m]	26.4								42.0																											
	5				25				45				60				[°]				5				25				45				60			
	[m]		[ton]		[m]		[ton]		[m]		[ton]		[m]		[ton]		[m]		[ton]		[m]		[ton]		[m]		[ton]		[m]		[ton]					
84	3.0	4.20	5.9	3.40	8.0	2.20	8.9	1.50	84	3.0	4.20	6.1	3.40	8.1	2.20	8.9	1.50	84	5.7	3.80	9.0	3.40	10.8	2.15	11.4	1.50										
83	3.7	4.20	6.6	3.40	8.6	2.15	9.4	1.50	83	3.7	4.20	6.7	3.40	8.6	2.15	9.4	1.50	81	8.9	3.80	11.9	3.10	13.4	2.05	13.9	1.50										
80	5.6	4.20	8.4	3.20	10.2	2.10	10.9	1.50	80	5.7	4.20	8.5	3.20	10.3	2.10	11.0	1.50	79	11.0	3.80	13.7	2.95	15.2	2.00	15.6	1.50										
77	7.5	4.20	10.2	3.00	11.8	2.00	12.4	1.50	77	7.6	4.20	10.2	2.95	11.9	2.00	12.5	1.50	76	14.1	3.80	16.5	2.80	17.7	1.95	18.0	1.45										
74	9.4	4.20	11.9	2.80	13.4	1.95	13.9	1.50	74	9.5	4.20	11.9	2.80	13.4	1.95	13.9	1.50	73	16.9	3.35	19.1	2.60	20.1	1.90	20.3	1.45										
72	10.7	4.20	13.0	2.70	14.4	1.90	14.8	1.45	72	10.8	4.20	13.0	2.70	14.5	1.90	14.8	1.45	70	19.5	2.90	21.6	2.35	22.5	1.85	22.6	1.40										
70	11.9	4.05	14.1	2.60	15.5	1.90	15.7	1.45	70	12.0	4.00	14.1	2.60	15.5	1.90	15.7	1.45	68	21.2	2.60	23.2	2.15	24.1	1.80	24.0	1.40										
67	13.6	3.65	15.8	2.45	16.9	1.85	17.1	1.45	67	13.7	3.65	15.7	2.50	16.9	1.85	17.1	1.45	67	22.0	2.40	24.0	2.10	24.8	1.80	24.7	1.40										
65	14.8	3.45	16.8	2.40	17.9	1.85	18.0	1.45	65	14.8	3.45	16.8	2.40	17.9	1.85	17.9	1.45	66	22.8	2.20	24.7	1.95	25.6	1.80	25.4	1.40										
63	15.9	3.25	17.8	2.35	18.8	1.80	18.8	1.40	63	15.9	3.25	17.8	2.35	18.8	1.80	18.8	1.40	64	24.1	1.85	26.1	1.65	27.0	1.60	26.8	1.40										
60	17.5	3.05	19.3	2.25	20.1	1.80			60	17.5	3.00	19.3	2.25	20.1	1.80			61	26.3	1.40	28.0	1.25	28.8	1.25												
57	19.0	2.80	20.7	2.20	21.3	1.80			57	19.1	2.80	20.7	2.20	21.3	1.80			58	28.3	0.95	30.0	0.90	30.6	0.90												
54	20.5	2.65	22.1	2.10	22.5	1.80			55	20.1	2.70	21.6	2.15	22.1	1.80			57	29.0	0.85																
51	21.9	2.20	23.3	2.05	23.6	1.80			53	21.1	2.60	22.4	2.10	22.9	1.80																					
49	22.8	2.00	24.1	1.85	24.3	1.80			50	22.4	2.45	23.7	2.05	23.9	1.80																					
47	23.6	1.75	24.8	1.65	25.0	1.65			47	23.7	2.30	24.8	2.00	24.9	1.80																					
45	24.4	1.55	25.5	1.50					44	25.0	2.15	25.9	1.95																							
40	26.3	1.15	27.2	1.15					42	25.8	2.00	26.6	1.90																							
35	28.0	0.85	28.7	0.85					40	26.5	1.85	27.2	1.80																							
30	29.5	0.55	29.8	0.55					35	28.2	1.55	28.6	1.55																							
26	30.5	0.40	30.6	0.40					30	29.6	1.30	29.8	1.30																							
25	30.8	0.35							26	30.6	1.15	30.5	1.15																							
									20	31.8	1.00																									
									15	32.4	0.90																									
[m]	BOOM 2 [%]	100								BOOM 2 [%]	0								BOOM 2 [%]	100																
	BOOM 3 [%]	33								BOOM 3 [%]	66								BOOM 3 [%]	100																
	BOOM 4 [%]	33								BOOM 4 [%]	66								BOOM 4 [%]	100																
	BOOM 5 [%]	33								BOOM 5 [%]	66								BOOM 5 [%]	100																
	MODE	A								MODE	B								MODE	A,B																
MIN [°]	24	25	46	62	MIN [°]	14	25	46	62	MIN [°]	56	57	57	63																						
CAPACITY [ton]	5								[ton]	5								[ton]	5																	
MASS [kg]	120								[kg]	120								[kg]	120																	
[Parts of line]	1								[Parts of line]	1								[Parts of line]	1																	

(Unit : Metric ton)

Based on ISO 4305
Not exceed 75% of static tipping loads

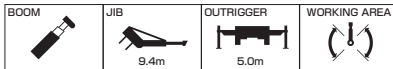

[m]	26.4								42.0																		
	5		25		45		60		5		25		45		60												
[°]	[m]	[ton]	[m]	[ton]	[m]	[ton]	[m]	[ton]	[m]	[ton]	[m]	[ton]	[m]	[ton]	[m]	[ton]											
84	3.0	4.20	5.9	3.40	8.0	2.20	8.9	1.50	84	3.0	4.20	6.1	3.40	8.1	2.20	8.9	1.50										
83	3.7	4.20	6.6	3.40	8.6	2.15	9.4	1.50	83	3.7	4.20	6.7	3.40	8.6	2.15	9.4	1.50										
80	5.6	4.20	8.4	3.20	10.2	2.10	10.9	1.50	80	5.7	4.20	8.5	3.20	10.3	2.10	11.0	1.50										
77	7.5	4.20	10.2	3.00	11.8	2.00	12.4	1.50	77	7.6	4.20	10.2	2.95	11.9	2.00	12.5	1.50										
74	9.4	4.20	11.9	2.80	13.4	1.95	13.9	1.50	74	9.5	4.20	11.9	2.80	13.4	1.95	13.9	1.50										
72	10.7	4.20	13.0	2.70	14.4	1.90	14.8	1.45	72	10.8	4.20	13.0	2.70	14.5	1.90	14.8	1.45										
70	11.9	4.05	14.1	2.60	15.5	1.90	15.7	1.45	70	12.0	4.00	14.1	2.60	15.5	1.90	15.7	1.45										
67	13.6	3.65	15.8	2.45	16.9	1.85	17.1	1.45	67	13.7	3.65	15.7	2.50	16.9	1.85	17.1	1.45										
64	15.3	3.35	17.3	2.35	18.3	1.80	18.4	1.40	65	14.8	3.45	16.8	2.40	17.9	1.85	17.9	1.45										
63	15.8	3.10	17.8	2.35	18.8	1.80	18.8	1.40	63	15.9	3.25	17.8	2.35	18.8	1.80	18.8	1.40										
61	16.8	2.65	18.8	2.30	19.7	1.80			60	17.5	3.00	19.3	2.25	20.1	1.80												
59	17.8	2.25	19.7	2.00	20.5	1.80			58	18.6	2.75	20.2	2.20	20.9	1.80												
57	18.9	1.95	20.6	1.70	21.3	1.65			56	19.6	2.40	21.1	2.15	21.7	1.80												
54	20.3	1.50	21.9	1.35	22.5	1.35			53	21.0	2.05	22.4	1.90	22.9	1.80												
51	21.7	1.15	23.2	1.10	23.6	1.05			50	22.3	1.70	23.6	1.60	23.9	1.60												
49	22.6	1.00	24.0	0.90	24.3	0.90			47	23.6	1.45	24.8	1.40	24.9	1.40												
47	23.5	0.80	24.7	0.75	24.9	0.75			45	24.5	1.30	25.5	1.25														
46	23.9	0.70	25.1	0.65					40	26.4	1.00	27.1	0.95														
									35	28.0	0.75	28.5	0.75														
									30	29.5	0.55	29.7	0.55														
									26	30.5	0.40	30.5	0.40														
									25	30.7	0.35																
[m]	BOOM 2 [%]	100								BOOM 2 [%]	0								BOOM 2 [%]	100							
	BOOM 3 [%]	33								BOOM 3 [%]	66								BOOM 3 [%]	100							
	BOOM 4 [%]	33								BOOM 4 [%]	66								BOOM 4 [%]	100							
	BOOM 5 [%]	33								BOOM 5 [%]	66								BOOM 5 [%]	100							
	MODE	A								MODE	B								MODE	A,B							
MIN [°]	45	45	46	62	24	25	46	62	66	66	66	66															
CAPACITY [ton]	5								[ton]	5								[ton]	5								
MASS [kg]	120								[kg]	120								[kg]	120								
[Parts of line]	1								[Parts of line]	1								[Parts of line]	1								

(Unit : Metric ton)



[m]	26.4								42.0																		
	5		25		45		60		5		25		45		60												
[°]	[m]	[ton]	[m]	[ton]	[m]	[ton]	[m]	[ton]	[m]	[ton]	[m]	[ton]	[m]	[ton]	[m]	[ton]											
84	3.8	3.00	8.3	2.50	11.4	1.40	12.8	0.90	84	3.9	3.00	8.5	2.50	11.4	1.40	12.9	0.90										
80	6.8	3.00	11.0	2.25	13.8	1.40	15.0	0.90	80	6.9	3.00	11.2	2.25	13.9	1.40	15.0	0.90										
78	8.2	3.00	12.3	2.15	15.0	1.40	16.0	0.85	79	7.6	3.00	11.8	2.20	14.5	1.40	15.5	0.85										
76	9.6	3.00	13.6	2.05	16.1	1.35	17.1	0.85	76	9.8	3.00	13.7	2.05	16.2	1.35	17.1	0.85										
73	11.7	2.85	15.4	1.95	17.8	1.30	18.6	0.85	73	11.9	2.85	15.6	1.95	17.9	1.30	18.6	0.85										
70	13.7	2.70	17.2	1.85	19.4	1.25	20.0	0.85	70	13.9	2.70	17.4	1.85	19.5	1.25	20.0	0.85										
67	15.7	2.60	19.0	1.75	20.9	1.20	21.4	0.80	67	15.9	2.60	19.1	1.75	21.0	1.20	21.4	0.80										
64	17.7	2.45	20.7	1.65	22.4	1.20	22.7	0.80	64	17.8	2.45	20.8	1.65	22.4	1.20	22.7	0.80										
61	19.5	2.30	22.3	1.60	23.8	1.15			62	19.0	2.35	21.9	1.60	23.3	1.15												
58	21.2	2.15	23.9	1.50	25.1	1.15			60	20.2	2.25	22.9	1.55	24.2	1.15												
55	22.9	2.00	25.3	1.45	26.3	1.10			57	22.0	2.10	24.5	1.50	25.6	1.15												
52	24.5	1.90	26.7	1.40	27.5	1.10			54	23.6	1.95	25.9	1.45	26.8	1.10												
50	25.6	1.85	27.6	1.40	28.2	1.10			51	25.2	1.85	27.3	1.40	27.9	1.10												
48	26.6	1.75	28.5	1.35	28.9	1.10			48	26.6	1.75	28.5	1.35	28.9	1.10												
47	27.0	1.75	28.9	1.35					45	28.1	1.70	29.7	1.35														
45	27.9	1.60	29.7	1.35					40	30.2	1.55	31.5	1.30														
42	29.2	1.40	30.7	1.30					35	32.1	1.45	33.0	1.30														
40	30.0	1.25	31.4	1.20					31	33.4	1.35	34.0	1.25														
35	31.9	0.90	32.9	0.90					29	34.0	1.30																
30	33.5	0.70	34.1	0.70					25	34.9	1.20																
26	34.6	0.50	34.9	0.50					20	35.9	1.05																
20	35.9	0.35							15	36.7	0.95																
[m]	BOOM 2 [%]	100								BOOM 2 [%]	0								BOOM 2 [%]	100							
	BOOM 3 [%]	33								BOOM 3 [%]	66								BOOM 3 [%]	100							
	BOOM 4 [%]	33								BOOM 4 [%]	66								BOOM 4 [%]	100							
	BOOM 5 [%]	33								BOOM 5 [%]	66								BOOM 5 [%]	100							
	MODE	A								MODE	B								MODE	A,B							
MIN [°]	19	25	47	63	14	30	47	63	53	53	53	63															
CAPACITY [ton]	5								[ton]	5								[ton]	5								
MASS [kg]	120								[kg]	120								[kg]	120								
[Parts of line]	1								[Parts of line]	1								[Parts of line]	1								

(Unit : Metric ton)

Based on ISO 4305
Not exceed 75% of static tipping loads

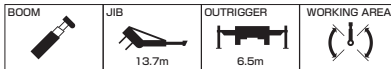

[m]	26.4								42.0																			
	5		25		45		60		5		25		45		60													
[°]	[m] [ton]		[m] [ton]		[m] [ton]		[m] [ton]		[m] [ton]		[m] [ton]		[m] [ton]		[m] [ton]													
84	3.8	3.00	8.3	2.50	11.4	1.40	12.8	0.90	84	3.9	3.00	8.5	2.50	11.4	1.40	12.9	0.90											
80	6.8	3.00	11.0	2.25	13.8	1.40	15.0	0.90	80	6.9	3.00	11.2	2.25	13.9	1.40	15.0	0.90											
78	8.2	3.00	12.3	2.15	15.0	1.40	16.0	0.85	79	7.6	3.00	11.8	2.20	14.5	1.40	15.5	0.85											
76	9.6	3.00	13.6	2.05	16.1	1.35	17.1	0.85	76	9.8	3.00	13.7	2.05	16.2	1.35	17.1	0.85											
73	11.7	2.85	15.4	1.95	17.8	1.30	18.6	0.85	73	11.9	2.85	15.6	1.95	17.9	1.30	18.6	0.85											
70	13.7	2.70	17.2	1.85	19.4	1.25	20.0	0.85	70	13.9	2.70	17.4	1.85	19.5	1.25	20.0	0.85											
67	15.7	2.60	19.0	1.75	20.9	1.20	21.4	0.80	67	15.9	2.60	19.1	1.75	21.0	1.20	21.4	0.80											
64	17.7	2.45	20.7	1.65	22.4	1.20	22.7	0.80	64	17.8	2.45	20.8	1.65	22.4	1.20	22.7	0.80											
61	19.5	2.30	22.3	1.60	23.8	1.15			62	19.0	2.35	21.9	1.60	23.3	1.15													
58	21.2	2.15	23.9	1.50	25.1	1.15			60	20.2	2.25	22.9	1.55	24.2	1.15													
55	22.9	2.00	25.3	1.45	26.3	1.10			57	22.0	2.10	24.5	1.50	25.6	1.15													
53	24.0	1.90	26.3	1.40	27.1	1.10			54	23.6	1.95	25.9	1.45	26.8	1.10													
51	25.1	1.85	27.2	1.40	27.8	1.10			51	25.2	1.85	27.3	1.40	27.9	1.10													
48	26.5	1.55	28.5	1.35	28.9	1.10			48	26.6	1.75	28.5	1.35	28.9	1.10													
47	26.9	1.45	28.9	1.35					45	28.1	1.70	29.7	1.35															
45	27.8	1.30	29.6	1.20					40	30.2	1.55	31.5	1.30															
40	29.9	0.95	31.4	0.95					36	31.7	1.30	32.7	1.30															
35	31.8	0.65	32.8	0.65					31	33.3	1.10	33.9	1.10															
29	33.7	0.40	34.3	0.40					25	34.9	0.95																	
28	34.0	0.35							20	35.9	0.80																	
									15	36.7	0.75																	
	BOOM 2 [%]									100									BOOM 2 [%]									100
	BOOM 3 [%]									33									BOOM 3 [%]									66
	BOOM 4 [%]									33									BOOM 4 [%]									66
	BOOM 5 [%]									33									BOOM 5 [%]									66
	MODE									A									MODE									B
MIN [°]	27	28		47		63		[°]	14	30		47		63		[°]	58	58		58		63						
CAPACITY [ton]									5									[ton]									5	
MASS [kg]									120									[kg]									120	
[Parts of line]									1									[Parts of line]									1	

(Unit : Metric ton)



[m]	26.4								42.0																			
	5		25		45		60		5		25		45		60													
[°]	[m] [ton]		[m] [ton]		[m] [ton]		[m] [ton]		[m] [ton]		[m] [ton]		[m] [ton]		[m] [ton]													
84	3.8	3.00	8.3	2.50	11.4	1.40	12.8	0.90	84	3.9	3.00	8.5	2.50	11.4	1.40	12.9	0.90											
80	6.8	3.00	11.0	2.25	13.8	1.40	15.0	0.90	80	6.9	3.00	11.2	2.25	13.9	1.40	15.0	0.90											
78	8.2	3.00	12.3	2.15	15.0	1.40	16.0	0.85	79	7.6	3.00	11.8	2.20	14.5	1.40	15.5	0.85											
76	9.6	3.00	13.6	2.05	16.1	1.35	17.1	0.85	76	9.8	3.00	13.7	2.05	16.2	1.35	17.1	0.85											
73	11.7	2.85	15.4	1.95	17.8	1.30	18.6	0.85	73	11.9	2.85	15.6	1.95	17.9	1.30	18.6	0.85											
70	13.7	2.70	17.2	1.85	19.4	1.25	20.0	0.85	70	13.9	2.70	17.4	1.85	19.5	1.25	20.0	0.85											
67	15.7	2.60	19.0	1.75	20.9	1.20	21.4	0.80	67	15.9	2.60	19.1	1.75	21.0	1.20	21.4	0.80											
64	17.7	2.45	20.7	1.65	22.4	1.20	22.7	0.80	64	17.8	2.45	20.8	1.65	22.4	1.20	22.7	0.80											
62	18.9	2.35	21.8	1.60	23.3	1.15			62	19.0	2.35	21.9	1.60	23.3	1.15													
59	20.6	1.85	23.4	1.55	24.7	1.15			60	20.2	2.25	22.9	1.55	24.2	1.15													
57	21.7	1.60	24.4	1.35	25.5	1.15			57	22.0	2.10	24.5	1.50	25.6	1.15													
55	22.7	1.35	25.3	1.20	26.3	1.10			55	23.0	1.90	25.5	1.45	26.4	1.10													
52	24.3	1.05	26.6	0.95	27.5	0.90			52	24.6	1.60	26.8	1.40	27.5	1.10													
50	25.3	0.90	27.5	0.80	28.2	0.80			50	25.6	1.40	27.7	1.30	28.2	1.10													
48	26.2	0.70	28.3	0.65	28.9	0.65			48	26.5	1.25	28.5	1.15	28.9	1.10													
47	26.7	0.60	28.7	0.55					45	27.9	1.05	29.6	1.00															
									40	30.0	0.80	31.4	0.75															
									35	31.8	0.55	32.9	0.55															
									31	33.1	0.40	33.9	0.40															
									29	33.7	0.35																	
	BOOM 2 [%]									100									BOOM 2 [%]									100
	BOOM 3 [%]									33									BOOM 3 [%]									66
	BOOM 4 [%]									33									BOOM 4 [%]									66
	BOOM 5 [%]									33									BOOM 5 [%]									66
	MODE									A									MODE									B
MIN [°]	46	46		47		63		[°]	28	30		47		63		[°]	66	67		67		67						
CAPACITY [ton]									5									[ton]									5	
MASS [kg]									120									[kg]									120	
[Parts of line]									1									[Parts of line]									1	

(Unit : Metric ton)

■ When outriggers are not used



[m]		10.8		18.6		26.4	
	WORKING AREA						
	3.0	16.50	9.75				
	3.5	14.55	7.55				
	4.0	12.95	6.05	10.00	6.70		
	4.5	11.60	4.95	10.00	5.55		
	5.0	10.45	4.10	10.00	4.70	7.80	4.90
	5.5	9.20	3.45	10.00	4.05	7.80	4.25
	6.0	7.85	2.95	8.60	3.55	7.80	3.70
	6.5	6.80	2.50	7.55	3.10	7.80	3.25
	7.0	5.95	2.15	6.70	2.75	6.90	2.90
	7.5	5.25	1.85	5.95	2.40	6.20	2.60
	8.0			5.35	2.15	5.55	2.30
	9.0			4.40	1.70	4.60	1.90
	10.0			3.70	1.35	3.85	1.55
	11.0			3.10	1.10	3.30	1.25
	12.0			2.65	0.85	2.85	1.05
	13.0			2.25		2.45	0.85
	14.0			1.95		2.15	0.70
	15.0			1.65		1.85	
16.0					1.65		
18.0					0.95		
20.0					0.75		
	BOOM 2 [%]	0		0		0	
	BOOM 3 [%]	0		33		66	
	BOOM 4 [%]	0		33		66	
	BOOM 5 [%]	0		33		66	
	MODE	A,B		B		B	
	MIN [°]	—	—	—	39	30	52
	CAPACITY [ton]	34					
	MASS [kg]	360					
	[Parts of line]	4					

(Unit : Metric ton)

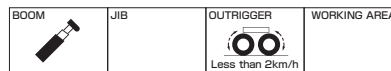

[m]		10.8		18.6		26.4	
	WORKING AREA						
	3.0	12.20	7.50				
	3.5	10.70	5.80				
	4.0	9.40	4.65	7.65	5.15		
	4.5	8.35	3.80	7.65	4.30		
	5.0	7.45	3.15	7.65	3.65	6.00	3.80
	5.5	6.70	2.65	7.65	3.10	6.00	3.25
	6.0	6.00	2.25	6.60	2.70	6.00	2.85
	6.5	5.25	1.90	5.80	2.35	6.00	2.50
	7.0	4.60	1.65	5.15	2.10	5.30	2.20
	7.5	4.05	1.40	4.60	1.85	4.75	2.00
	8.0			4.10	1.65	4.30	1.75
	9.0			3.40	1.30	3.55	1.45
	10.0			2.85	1.05	2.95	1.20
	11.0			2.40	0.85	2.55	0.95
	12.0			2.05	0.65	2.20	0.80
	13.0			1.75		1.90	0.65
	14.0			1.50		1.65	
	15.0			1.30		1.45	
16.0					1.25		
18.0					0.75		
20.0							
	BOOM 2 [%]	0		0		0	
	BOOM 3 [%]	0		33		66	
	BOOM 4 [%]	0		33		66	
	BOOM 5 [%]	0		33		66	
	MODE	A,B		B		B	
	MIN [°]	—	—	—	39	38	55
	CAPACITY [ton]	34					
	MASS [kg]	360					
	[Parts of line]	4					

(Unit : Metric ton)

Minimum path width

● Left turn in two-wheel steering mode

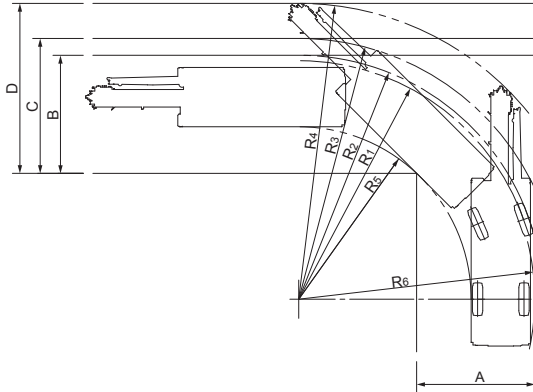

- $R_1=11.70\text{m}$
(Minimum turning radius)
- $R_2=12.00\text{m}$
(Turning radius of extremely outer tire)
- $R_3=12.80\text{m}$
(Chassis turning radius)
- $R_4=14.50\text{m}$
(Boom end turning radius)
- $R_5=8.40\text{m}$
(Turning radius extremely chassis inner)

- $R_6=11.60\text{m}$
(Turning radius at the rear end of the chassis)
- $A=5.78\text{m}$ (Width of entrance)
- $B=5.78\text{m}$ (Width of wheel exit)
- $C=6.60\text{m}$ (Width of chassis exit)
- $D=8.32\text{m}$ (Width of exit at end of boom)

● Left turn in 4-wheel steering mode

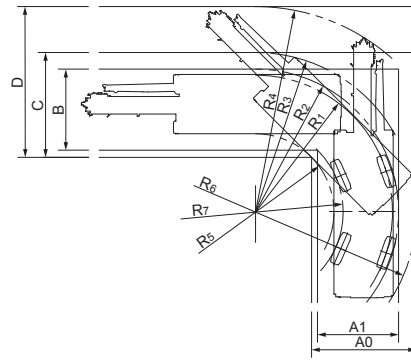

- $R_1=6.70\text{m}$
(Minimum turning radius)
- $R_2=7.00\text{m}$
(Turning radius of extremely outer tire)
- $R_3=7.80\text{m}$
(Chassis turning radius)
- $R_4=10.10\text{m}$
(Boom end turning radius)
- $R_5=3.80\text{m}$
(Turning radius extremely chassis inner)

- $R_6=7.90\text{m}$
(Turning radius at the rear end of the chassis)
- $R_7=4.20\text{m}$
(Turning radius of extremely inner tire)
- $A_0=5.13\text{m}$ (Width of chassis entrance)
- $A_1=4.00\text{m}$ (Width of wheel entrance)
- $B=4.00\text{m}$ (Width of wheel exit)
- $C=5.13\text{m}$ (Width of chassis exit)
- $D=7.38\text{m}$ (Width of exit at end of boom)

Note: The above values are based on calculations.

Overall view

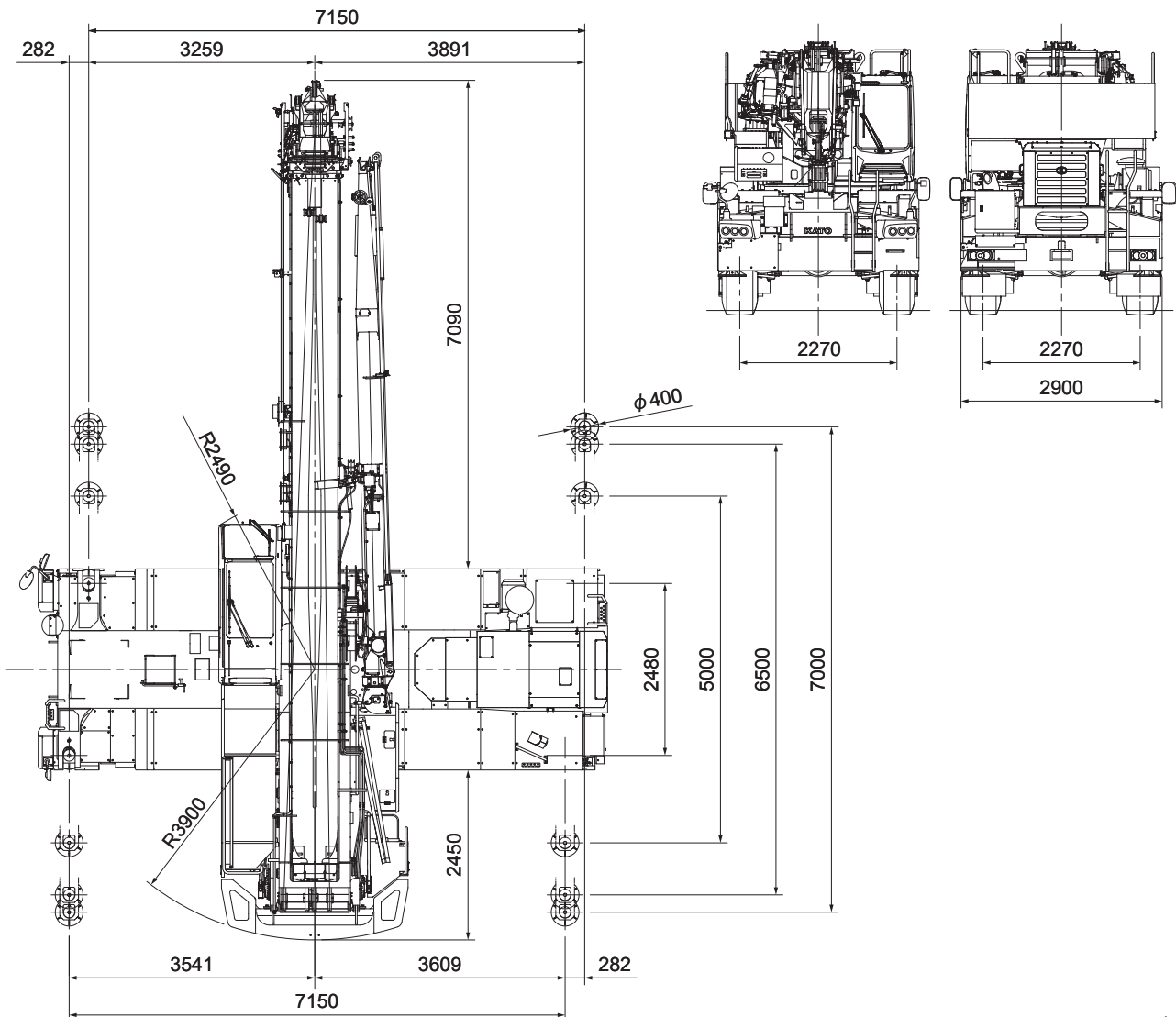

Reduced scale: 1/100 Unit (mm)

Overall view

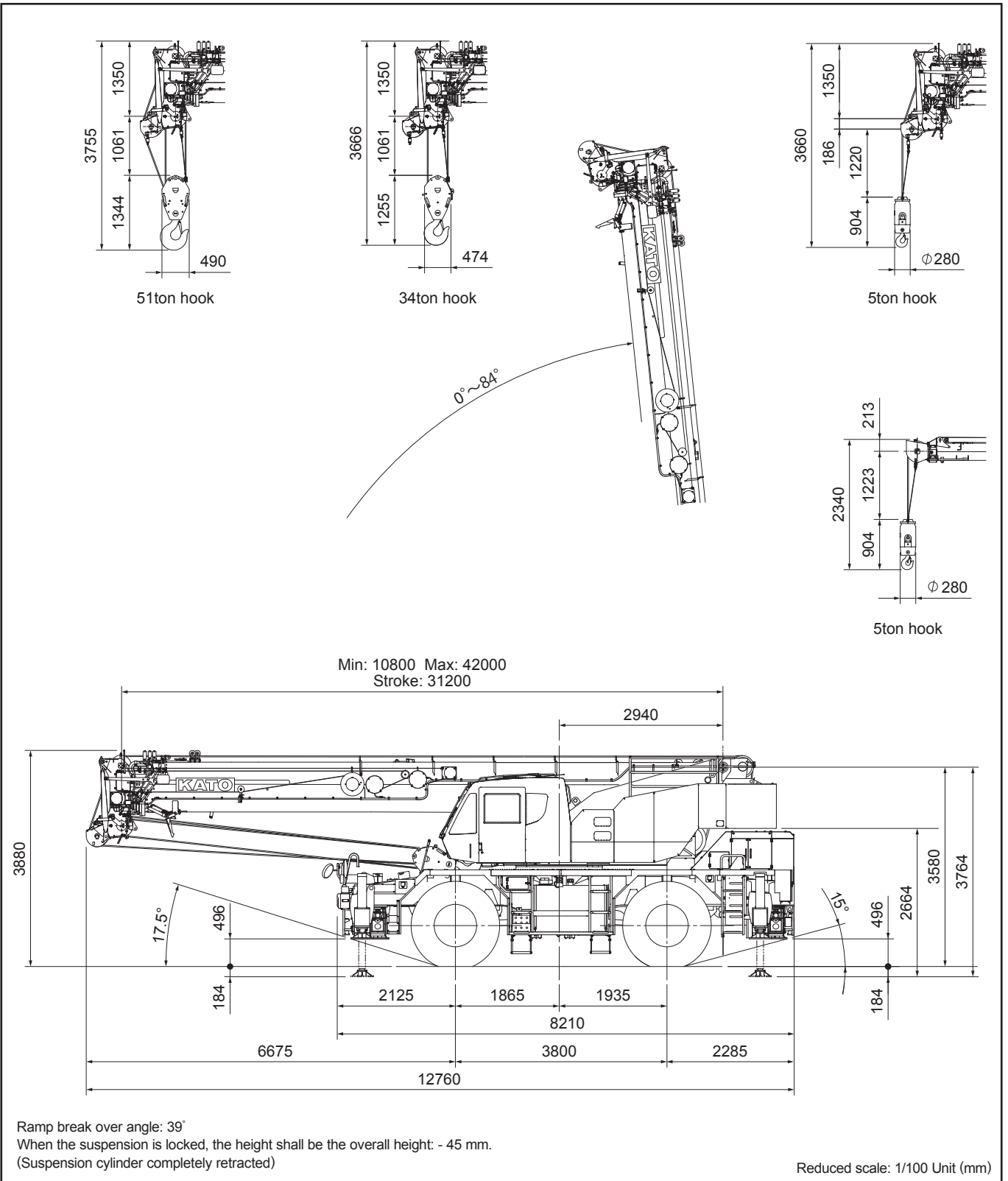

* KATO products and specifications are subject to improvements and changes without notice.

Address inquiries to:

KATO

KATO WORKS CO.,LTD.

9-37, Higashi-ohi 1-chome, Shinagawa-ku, Tokyo, 140-0011, Japan

Tel. : Head Office Tokyo +81 (03) 3458-1111
Overseas Marketing Department. Tokyo +81 (03) 3458-1115

Fax. : Tokyo +81 (03) 3458-1152

URL <http://www.kato-works.co.jp>

C03401

9.2019-2000 (TI) 1